

FRONT AXLE/SUSPENSION ESTELLE/RAPID

STEERING ANGLES

ALL angles to be tested in the semi-laden condition using MP6 160A under the top wishbone as shown.

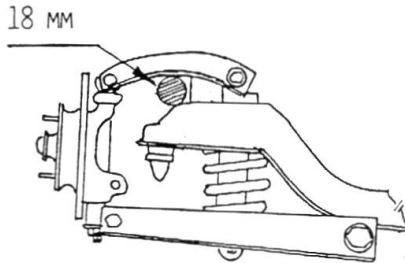

TRACKING

Toe out on turns

Outside wheel 20°
Inside wheel 23° ± 30'

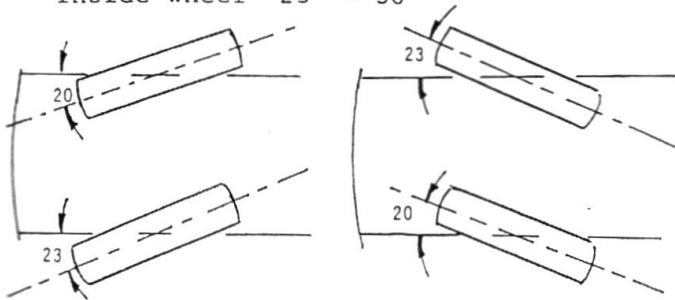

Before checking track, ensure wheels are directly fore and aft.

Full Lock
Outside Wheel 29° 30'
Inside Wheel 37°

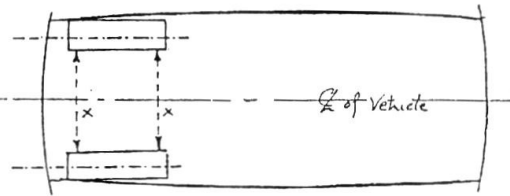

Estelle/Rapid Track setting 13 inch wheels 0-3MM TOE IN
14 INCH WHEELS 1-4MM TOE IN

INITIAL SETTING OF STEERING RODS

Saloon up to 1983

Rapid up to 1984

Saloon from 1984

Rapid from 1985 from 1985

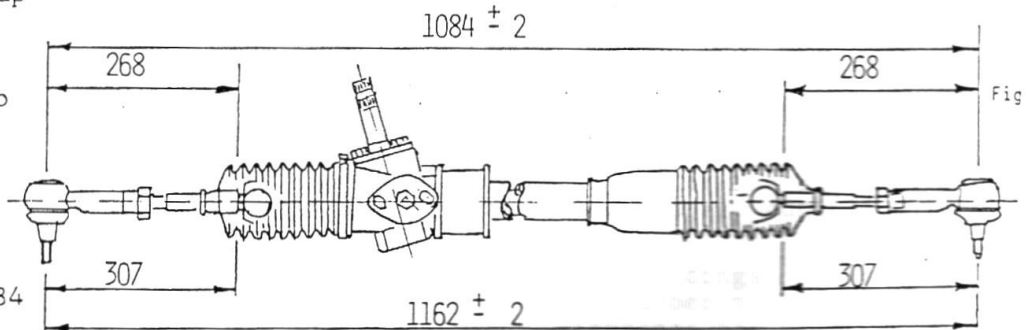

Outer steering rods to be adjusted equally when adjusting track.